

# **MICROCALORIMETRIC STUDIES OF THE STRUCTURE OF SUPPORTED BIMETALLIC CATALYST PARTICLES**

## **A review**

*J. Phillips*

The Pennsylvania State University, Department of Chemical Engineering, 133 Fenske Lab., University Park, Pennsylvania 16802-4400, USA

### **Abstract**

Microcalorimetric studies of oxygen and hydrogen chemisorption during the last decade improved the understanding of the structure and structural dynamics of supported bimetallic catalyst particles. For example, it was found that on graphitic supports two different reduced surface compositions/structures can be created for base metal/noble metal particles. Appropriate treatments "switch" the surface from almost pure reduced base metal to true alloy. Calorimetric studies also indicate support interactions play a major role in controlling bimetallic particle surface structure. In contrast to behaviour found on graphitic supports, iron/noble metal particles supported on refractory oxides apparently do not form alloy surfaces. The reduced surface is dominated by the noble metal. Several studies indicate the value of the models of surface composition/structure developed using microcalorimetry for predicting the activity/selectivity of bimetallic particles.

**Keywords:** adsorption, bimetallic, catalyst, microcalorimetry, particle structure

### **Introduction**

Microcalorimetry plays a significant role in a number of catalyst characterizations. The widest application of the technique in catalysis is to probe acid catalyst surfaces, but it is used to study metal catalyst structure and the surface chemistry of carbon catalyst supports as well. Several recent and thorough reviews of the use of calorimetry to probe solid acid catalysts are available [1, 2]; however, there is no review of the other applications. Yet, calorimetry played a significant role in recent years in advancing the understanding of bimetallic catalyst structure and the chemistry of carbon supports [3-6]. Thus, the goal of the present work is to provide an outline of the use of calorimetry in one of these areas. Specifically, the following brief survey is focused on the use of microcalorimetry to elucidate the structure of bimetallic catalysts.

One of the most vexing problems in catalysis is the structure of bimetallic and multimetallic catalysts. In particular, surface composition of supported particles is difficult to determine from conventional techniques such as adsorption isotherms, as well as from various electron spectroscopies (XPS and Auger). Adsorption tech-

niques only probe the amount of gas adsorbed, but provide no information regarding surface composition. Attempts to deconvolute such data to obtain surface composition are interesting, but not compelling [7-9]. Electron spectroscopies are "surface sensitive" only in a relative sense. They do not provide reliable information regarding composition variations in the top five to ten atomic layers. Yet, from the point of view of predicting or understanding catalytic behaviour of supported metal particles it is critical that the composition of the very outermost layer be reliably determined. Other techniques hold promise, but little evidence of delivery is available. For example, on many modern transmission electron microscopes (TEM) energy dispersive analysis of X-ray (EDAX) systems are available. Some attempts have been made to use this technique to probe for surface composition of bimetallic particles, but the interpretation of the data requires numerous assumptions. Calorimetry appears to be by far the best technique available for probing the surface composition of the "catalytic layer" of supported metal particles.

Finally, it is important to recognize the fact that calorimetry alone is not sufficient to fully characterize multimetallic catalyst structure. Calorimetry is generally employed as part of a collection of techniques that together yield important structural information. For example, X-ray diffraction [10], EXAFS [11], and Mössbauer spectroscopy [12, 13] have all been used to provide "bulk" behaviour information about supported bimetallic particles which is complementary to "surface" calorimetric data. Also, catalytic activity and selectivity have been used in conjunction with microcalorimetry to help "verify" the conclusions reached using calorimetry [14]. Indeed, in the catalysis community it is an axiom that several techniques must be employed to "solve" structural problems.

### Microcalorimeters for catalysis

In modern work only Calvet-style heat flow calorimeters are used for the study of supported catalyst particles. Other techniques, such as a modified adiabatic thin film calorimeter [15-17], were used in the past.

Calvet style instruments employed in calorimetry are designed to measure both the amount of gas adsorbed during a differential gas dose and the heat which is evolved as a result of the adsorption process. The former is measured using standard isotherm technology. That is, changes in the gas pressure are measured once the "dosing" chamber (Fig. 1) is exposed to the "sample" chamber. The amount of adsorbed gas is computed by determining the difference between measured final pressure and that predicted from the ideal gas law. The heat released by the adsorption process is measured on the basis of the heat-flow concept. Heat evolved in the sample chamber due to adsorption "flows" out of the chamber and through thermopiles to heat sinks. The thermopiles produce a signal that is proportional to the rate at which heat is flowing and this signal integrated over time, yields the total heat generated [1, 18].

There are several examples of calorimeters for the study of gas adsorption designed and built by investigators, rather than purchased commercially [19, 20].

Many of these were inspired by an instrument designed and built by the author and collaborators [3, 21, 22].

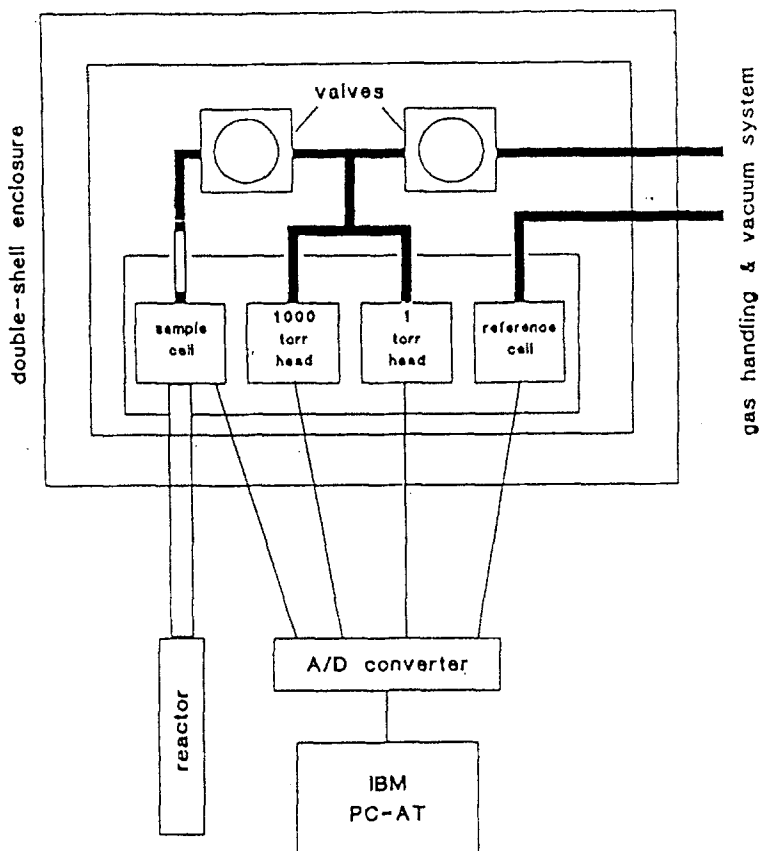
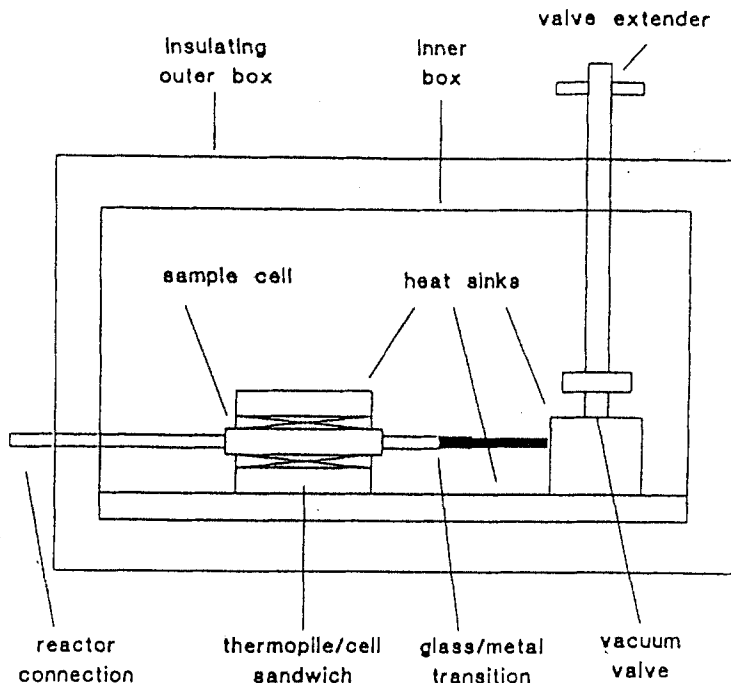

**Fig. 1a** Schematic diagram of a differential adsorption microcalorimeter design.  
Overhead view: the dosing volume which includes the Baratron pressure heads, is located between the two valves

As shown in Fig. 1, the heart of the instrument consists of a flat, cylindrical sample chamber sandwiched between two thermopiles. Heat generated in the sample cell as a result of a chemical process (e.g., gas adsorption) travels through the thermopiles and then to the heat sinks. It is worth noting that for calorimeters designed to operate at less than 373 K, generally acceptable for the study of supported metal catalysts, there are inexpensive commercially available thermopiles with excellent performance characteristics (e.g. high voltage-out/watts-in ratio). This sample chamber is attached both to a quartz sample preparation reactor and a dosing volume consisting of two baratron pressure gauge heads and associated plumbing. The preparation reactor is required as it permits samples to be treated at very high temperature and then transferred to the sample chamber by "gravity feed". The

pressure gauge heads in the dosing volume allows very precise determination of the number of moles present in the gas phase before and after adsorption.

The fact that the sample and dosing volumes are at the same temperature (surrounded by the same oven) eliminates uncertainties in heat and mole computations. For example, in systems in which the dosing volume temperature (e.g. 300 K) is not at the same temperature as the sample chamber (e.g. 450 K) concern regarding heat values is justified. How much adsorption heat is lost to "heating" the incoming gas aliquots? Finally, it should be noted that baseline stability requires that the entire apparatus be well-insulated and placed in an "oven" in which temperature is precisely controlled.



**Fig. 1b** Schematic diagram of a differential adsorption microcalorimeter design. Side view: view of the sample cell, showing the thermopile "sandwich", in which the sample cell is sandwiched between the thermopiles and the heat sinks. [After R. R. Gatte, Ph. D. Thesis, Penn State University, 1988, with permission.]

## Microcalorimetric study of multimetallic catalysts

Even a decade ago there was little understanding of the structure of bimetallic catalysts. As outlined by Niemantsverdriet [23], there were several variations on a single theme in the early models. In essence, it was postulated that even after a high temperature reduction the particles consisted of an "oxide" zone at the support/particle interface and an "alloy" above. Only one model was significantly different. In

that model it was suggested that the particles consisted only of two alloys of different character, one a "bulk" alloy and the second a "surface" alloy [24]. Moreover, it appears little consideration was given to the role played by support interactions.

There has been considerable advance in understanding the structure of bimetallic catalysts in the last decade. Calorimetric studies in particular, but also studies employing extended X-ray analysis of fine structure (EXAFS), X-ray diffraction (XRD) and Mössbauer Spectroscopy (MES) improved the general understanding. It is now believed that the structure of bimetallic particles is a function of the support material and the treatment sequence. For example, one cannot simply speak of a single model of particle structure on a graphitic support. It is clear that particle structure is "dynamic", and thus a variety of structures form as a function of treatment sequence. Also, it is clear the structure of bimetallic particles on refractory oxide supports is totally different than the structure of particles of the same composition on high surface area graphitic carbons.

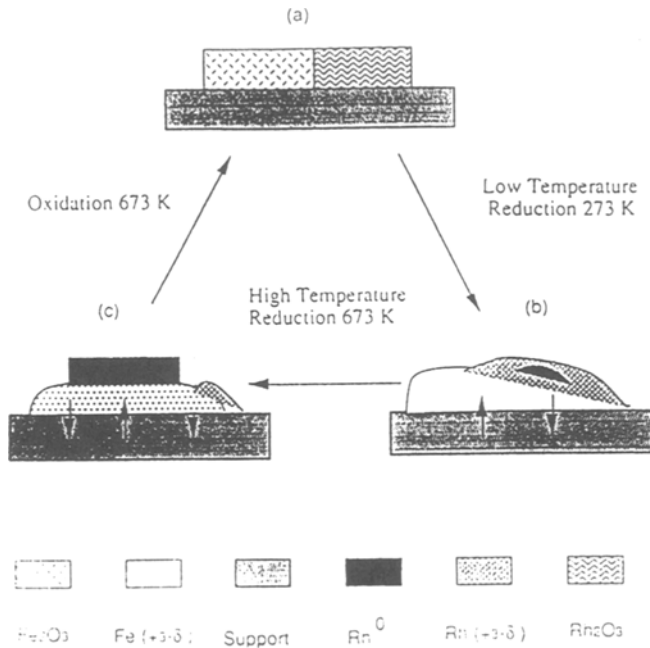

**Fig. 2** Schematic model of particle dynamics proposed for Fe-Rh on refractory oxides. a) Immiscible oxides formed after oxidation at 673 K. b) Partially (or non-) reduced oxides formed after LTR. A small amount of rhodium is reduced to its zero-valent state. c) Surface enrichment in rhodium following HTR. Iron oxide stays at the metal-support interface as a platform to reduced rhodium [After S. M. da Silva, M. S. Thesis, Penn State University, 1993, with permission.]

On refractory oxide supports there is increasing evidence that in a bimetallic particle consisting of a base metal and a noble metal, the base metal is preferentially found at the particle support interface. This is the metal which reacts most strongly with the refractory oxide support. This metal forms a strong bond with the

support, possibly forming an aluminate or silicate structure, for example [25, 26]. The less interactive noble metal is found on top of this layer and generally dominates the catalytic behavior. In fact, it has been suggested that the surface metal is "screened" from interaction with the support [27]. That is, the metal which interacts more strongly with the support acts to reduce the strength of interaction between support and the noble metal. Thus the surface noble metal in particles of this category is sometimes more easily reduced than in the case in which it alone is present.

A well-researched example of the behaviour of base metal/noble metal particles on refractory oxide supports is the iron-rhodium system supported on alumina. As shown in Fig. 2, the iron interacts strongly with the support and in consequence is never fully reduced. In fact, it is possible that the iron is in the form of an aluminate [25, 26]. In contrast, the rhodium forms a metallic phase on top, and there is evidence that the degree to which the rhodium is reduced is greater than it is in the case in which the same support is impregnated with rhodium, and only rhodium, to the same level of loading [27]. A calorimetric study of the FeRh/Al<sub>2</sub>O<sub>3</sub> system after low temperature and high temperature reduction is fully consistent with the above model and is a key part of the data which supports the model (Fig. 3).

Clearly this model of particle structure differs significantly from the earlier models. The most significant difference is that the new model indicates no alloy

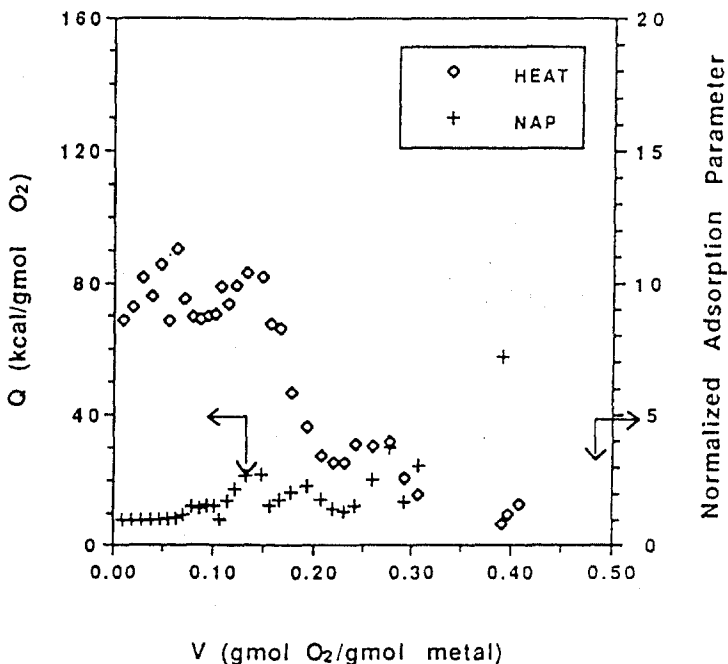
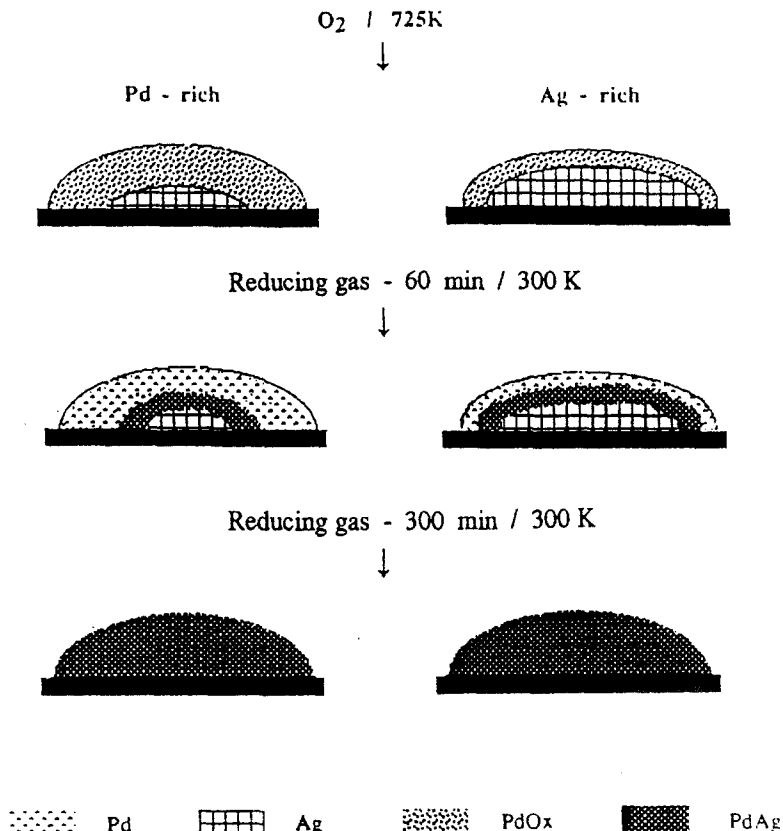

Fig. 3 Differential heat of oxygen adsorption (at 303 K) on Fe-Rh/Alumina following reduction at 673 K. The measured heats are similar to those of metallic rhodium, not at all like iron (see Fig. 5). Note, virtually no oxygen adsorbed after reduction at lower temperatures. The relative rate of adsorption is inverse to NAP. [After S. M. da Silva, M. S. Thesis, Penn State University, 1993, with permission.]

formation at all. The relative strength of interaction between one metal and the support apparently prevents the formation of an alloy. The catalytic surface is reduced metal, but not an alloy.

Systems composed of two noble metals supported on refractory oxides sometimes behave differently. It appears that in this case both metals are completely reduced, allowing true alloy to form. A simple example of this type of behaviour is the Pd-Ag/SiO<sub>2</sub> system [28]. The behaviour of this system as a function of treatment is shown in Fig. 4. This result suggests a general rule: In cases in which metal-support interactions are not strong behaviour predicted for "bulk" metal alloys apparently will be observed. As discussed below, this is clearly the case for many base-metal/noble metal particles supported on graphite. It should be noted that the models have not been tested at high metal loadings (ca. > 5 wt%) or away from near 1:1 stoichiometry.

The behaviour of base metal/noble metal systems supported on graphitic supports has been thoroughly studied. It has repeatedly been shown that the structure of these particles is totally different from that of the same two metals on a refrac-



**Fig. 4** Model of Pd/Ag phase behavior after initial high temperature oxidation. Note, alloy forms from segregated phases in reducing atmosphere at 300 K

tory oxide support. An example is the structure of iron–rhodium particles on a graphitic support. This system was thoroughly studied using microcalorimetry, XRD and MES [10, 29]. As with all systems of this type the behaviour of bulk alloys of the same two metals is the best guide to the behaviour of the supported particles.

The first step in making a catalyst is a calcination/oxidation. Oxidation ( $> 473$  K) of FeRh/Graphite clearly leads to the formation of individual particles each containing segregated zones of iron oxide and rhodium oxide. This is not surprising given:

- i) the postulate that these systems follow bulk behavior,
- ii) the fact that there is no known bulk oxide phase containing both iron and rhodium.

It was also suggested that the rhodium oxide is preferentially in the interior and, the iron oxide at the particle surface. This is not due to a parallel to behaviour observed on refractory oxide support. Indeed, all evidence indicates that the Grafoil–rhodium interaction is weak. The arrangement of oxide phases on Grafoil results from the mechanism of each metal oxidation. The mobile species in iron oxidation is the iron cation. Rhodium oxidizes via a co-diffusion process. The net result is that iron preferentially diffuses to the surface during oxidation [30].

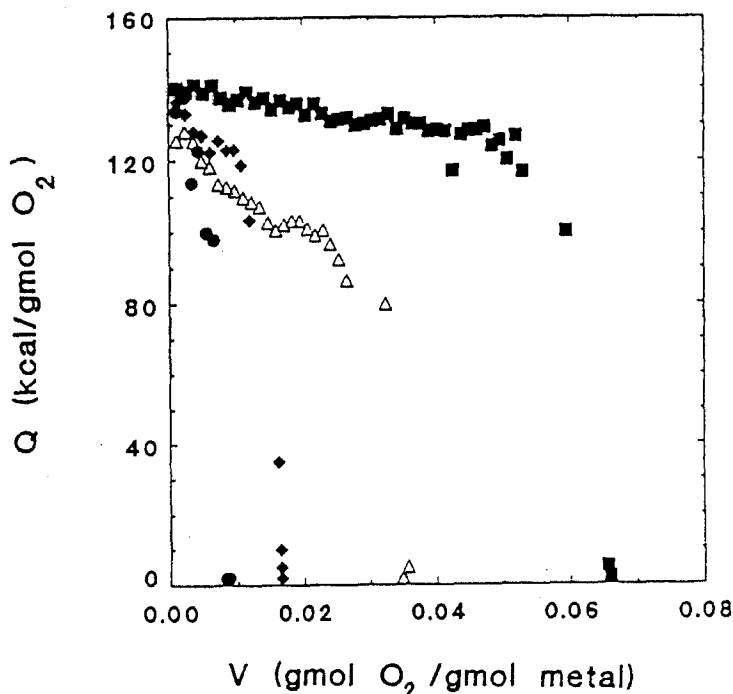

Fig. 5a Differential heat of oxygen adsorption (at  $30^{\circ}\text{C}$ ) on FeRh/Grafoil after 473 K oxidation and  $30^{\circ}\text{C}$  reduction (closed circles), 373 K reduction (closed squares), a subsequent 300 K reduction (closed diamonds), and a final reduction at 673 K (open triangles)



The state of FeRh/Graphite was then studied after a low temperature (373 K) reduction. MES and XRD clearly showed that both metallic iron and metallic rhodium are present after this treatment. However, it was only microcalorimetry which was able to probe the surface composition. The microcalorimetric results suggested that the particle surfaces were about 90 atomic percent reduced metallic iron. Indeed, not only were the heats of adsorption similar to those of metallic iron, but the stoichiometry of adsorption was also characteristic of metallic iron (Fig. 5a). The behaviour is consistent with the kinetics of transformations of bulk alloys. That is, the low temperature reduction is not carried out at a temperature which permits the metals to form a thermodynamically stable alloy, but at a temperature which will allow each to reduce "in place". Since ironoxide is preferentially found on the surface after particle oxidation, from metal is dominant on the surface after low temperature reduction. In sum, low temperature reduction led to the creation of a metastable (not predicted by phase diagram) segregated metals structure.

Oxygen adsorption microcalorimetry very clearly shows the changes in the surface composition after high temperature reduction (Fig. 5b). After this process the surface adsorbs with a heat between that of rhodium and iron, and with a stoichiometry like that of a noble metal (Fig. 5a). Only high temperature reduction provides the energy necessary for metal diffusion and hence the formation of the true

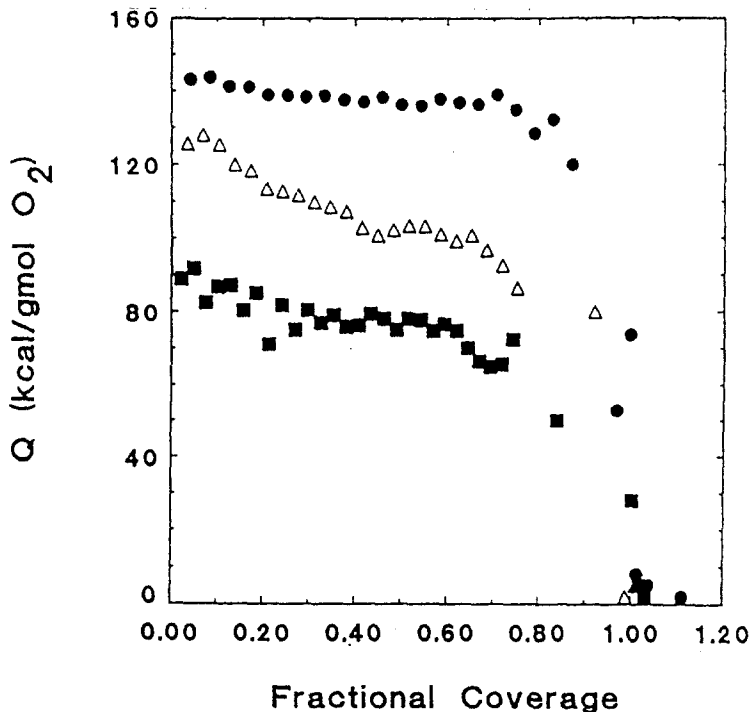
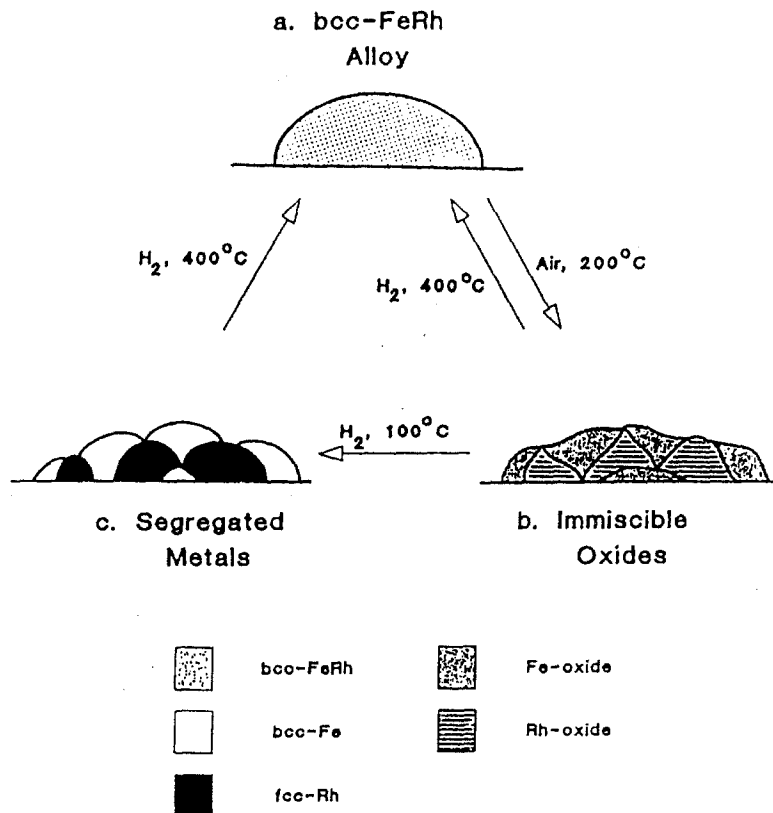

Fig. 5b Comparison between differential heat of oxygen adsorption on Fe/Grafoil (closed circles), Rh/Grafoil (closed squares) and FeRh/Grafoil. The fractional coverage is obtained by normalizing the data by the total amount of irreversibly adsorbed oxygen for each sample

alloy, predicted by bulk phase diagram [31]. Figure 5c is a schematic representation of the structures believed to be present after the various treatments. It is interesting to note that a number of catalytic studies were performed using the iron–rhodium catalyst after the different treatments, and that the results of these studies (activity, selectivity) are entirely consistent with the surface structure/compositions revealed by microcalorimetry [14, 32]. Indeed, the catalytic behavior, in particular the selectivity, was found to be far different from that observed for either metal alone, or for the same bimetallic couple on a refractory oxide support. This last result is not surprising given that only on the weakly interacting support did a true surface alloy form.

Calorimetric, XRD, TEM and MES studies of graphite supported iron-iridium [33], and iron palladium [34, 35] were also carried out. In each equimolar metal case calorimetric studies of oxygen adsorption revealed that the surface was primarily metallic iron after a low temperature reduction and a bulk alloy after a high temperature reduction. In a case in which excess iron was present, both an alloy phase and a metallic iron phase were found at the surface, in agreement with behaviour



**Fig. 5c** Schematic model of the proposed particle dynamics for Fe/Rh Grafoil. a) Uniform bcc-FeRh alloy formed during 673 K reduction, b) segregated immiscible oxides ( $\text{Fe}_2\text{O}_3$  and  $\text{Rh}_2\text{O}_3$ ) formed during 473 K oxidation, showing the iron-enrichment of the surface, c) segregated metals formed during 373 K reduction of the previously oxidized sample, again showing the iron-enrichment of the surface

anticipated from the bulk phase diagram. In sum, it can be stated that the phase behaviour of these graphite supported bimetallic particles is similar to that of the graphite supported iron-rhodium system.

The iron-palladium systems are of particular interest because hydrogen adsorption microcalorimetry was also employed as a structure probe. This method works as hydrogen will form hydrides with palladium (as shown by calorimetry [36–38]). Thus the method was useful for probing the character of the palladium rich phases which were present after different treatments. For example, it was clear that the palladium remained metallic even after oxidation. It was also shown that the gradual inclusion of iron into the palladium changed the heat of hydride formation.

## Conclusions

Over the past decade calorimetry has been used repeatedly to probe the surface composition of bimetallic particles on both refractory oxide supports and graphitic supports. In conjunction with bulk structure probes such as EXAFS, MES and XRD these studies reveal that phase segregation occurs within individual particles. This occurs for a variety of reasons, with a variety of catalytic consequences. One major finding is that only on graphitic supports will true base metal/noble metal alloy surfaces form. Another finding is that on graphitic surfaces at least two distinct reduced surfaces can be created. In contrast, on refractory oxide supports the noble metal dominates the surface and hence controls the catalytic behaviour and only one reduced surface structure is ever achieved. Thus, calorimetry revealed the structural consequences of weak metal support interactions (WMSI), the typed interaction found between metals and graphitic supports. This suggested hitherto unsuspected catalytic consequences to support selection. In fact, probe reactions verified unique activity and selectivity behaviour for graphite supported base metal/noble metal bimetallic particles [14, 22, 32].

Additional study is required to complete the understanding of bimetallic particle structure. Microcalorimetric and 'bulk' technique studies of the structure of bimetallic particle supported on a variety of carbon supports (e.g., activated carbon, carbon black) could yield insight into the consequences of subtle changes in metal support interaction on catalyst particle structure. Also, studies in which a metal other than iron is the "base metal" are needed to test the generality of the "dynamic" structure models. Finally, structural studies at metal compositions away from near 1:1 stoichiometry are needed.

## References

- 1 J. A. Dumesic and N. Cardona-Martinez, *Adv. in Catalysis*, 38 (1992) 149.
- 2 W. E. Farneth and R. J. Gorte, *Chem. Rev.*, 95 (1995) 615.
- 3 M. K. O'Neil and J. Phillips, *J. Phys. Chem.*, 91 (1987) 2867.
- 4 F. G. Keyes and M. J. Marshall, *J. Am. Chem. Soc.*, 49 (1927) 156.
- 5 A. S. Gow and J. Phillips, *Energy and Fuels*, 6 (1992) 184.
- 6 L. Radovic, J. A. Menendez-Diaz, B. Xia and J. Phillips, *Langmuir*, 12 (1996) 4404.
- 7 T. Paryjczak and P. A. Zielinski, *Polish J. of Chem.*, 57 (1983) 1303.

- 8 H. Minai, T. Suzuki, K. Ushikabo, T. Sugiyama, T. Matsuda and R. D. Gonzalez, *J. Catal.*, 85 (1984) 331.
- 9 S. Alerasool, D. Boecker, B. Rejai, R. D. Gonzalez, G. del Angel, A. Azomasa and R. Gomez, *Langmuir*, 4 (1988) 1083.
- 10 R. R. Gatte and J. Phillips, *J. Catal.*, 116 (1989) 49.
- 11 T. Mizushima, K. Tohji, Y. Udagawa, M. Havada, M. Ishikawa and A. Ueno, *J. Catal.*, 112 (1988) 282.
- 12 Y. Minai, T. Tominaga, T. Fukushima and M. Ishikawa in "Industrial Applications of the Mössbauer Effect" (Ed. G. J. Long and J. G. Sterens) Plenum Press, NY 1986, p. 635.
- 13 J. W. Niemantsverdriet, A. M. Van der Kraan and W. N. Delgass, *J. Catal.*, 89 (1984) 138.
- 14 H. Durr and J. Phillips, *J. Catal.*, 126 (1990) 619.
- 15 J. M. Thomas and W. J. Thomas, *Introduction to the Principles of Heterogeneous Catalysis*, Academic Press, London 1967, p. 102.
- 16 W. E. Garner and F. J. Veal, *J. Chem. Soc.*, 1436 (1935).
- 17 R. L. Gale, J. Harber and F. S. Stone, *J. Catal.*, 1 (1962) 32.
- 18 P. C. Gravelle, *Adv. in Catalysis*, 22 (1972) 191.
- 19 P. J. Andersen and H. H. Kung, *J. Phys. Chem.*, 96 (1992) 3114.
- 20 D. J. Parrillo, C. Lee and R. J. Gorte, *Appl. Catal. A*, 110 (1994) 67.
- 21 M. K. O'Neil, R. Lovrien and J. Phillips, *Rev. Sci. Instr.*, 56 (1985) 2312.
- 22 R. R. Gatte and J. Phillips, *Langmuir*, 5 (1989) 758.
- 23 J. W. Niemantsverdriet, J. A. C. van Kaam, C. F. J. Flipse and M. A. Van der Kraan, *J. Catal.*, 96 (1985) 58.
- 24 R. L. Garten, *J. Catal.*, 43 (1976) 18.
- 25 M. V. Cagnoli, R. Magglovi, G. Schembari, S. Scire and S. Galgrano, *J. Mol. Catal.*, 50 (1989) 67.
- 26 H. Topsøe, J. A. Dumesic, and S. Morup in "Applications of Mössbauer Spectroscopy", Vol. II (Ed. R. Cohen) Academic Press, NY 1980, p. 56.
- 27 S. M. da Silva and J. Phillips, *J. Mol. Catal.*, 94 (1994) 97.
- 28 A. Auroux, J. Phillips, G. Bergeret, J. Massadier and A. Renouprez, *J. Phys. Chem.*, 97, (1993) 3565.
- 29 R. R. Gatte and J. Phillips, *J. Catal.*, 116 (1989) 49.
- 30 O. Kubaschewski and B. E. Hopkins, "Oxidation of Metals and Alloys", Butterworth, London 1967.
- 31 O. Kubaschewski, "Iron Binary Phase Diagrams", Springer-Verlag, Berlin 1988.
- 32 J. Phillips, P. Gallezot and G. Bergeret, *J. Mol. Catal.*, 78 (1993) 295.
- 33 J. W. Cobes and J. Phillips, *J. Phys. Chem.*, 95 (1991) 5545.
- 34 R. W. Wunder and J. Phillips, *J. Phys. Chem.*, 98 (1994) 12239.
- 35 R. W. Wunder and J. Phillips, *J. Phys. Chem.*, 100 (1996) 14430.
- 36 R. W. Wunder, J. W. Cobes, J. Phillips, L. R. Radovic, A. J. Lopez-Peinado and F. Carrasco-Marin, *Langmuir*, 9 (1993) 984.
- 37 J. F. Lynch and T. B. Flanagan, *J. Chem. Soc. Faraday Trans. I*, 20 (1974) 814.
- 38 S. V. Artamatov, G. D. Zakumbaeva and D. V. Soklo'skii, *Dulk Acad. Nauk. SSSR*, 224 (1979) 123.